



Carat XXL Underground Tank

The new dimension

16.000 TO 100.000 LITER

Lorry-bearing up to
SLW 40



RAINWATER TANKS

FIREFIGHTING WATER TANKS

RETENTION CISTERNS

PROCESS WATER TANKS



Production site at Teningen (Germany)



Production site at Dachstein (France)

GRAF – the market leader with superior quality

For more than 50 years, the GRAF brand has represented high-quality plastic products. The company launched the first products for rainwater harvesting in 1974 – a breakthrough at the time. Today, GRAF offers an extensive range of products for water resource management.

Commitment to Germany as our corporate site

GRAF continually invests in the development of its headquarters in Teningen, Germany. Covering an area of 155,000 square metres – equivalent to 31 football pitches – it is one of the world's most modern manufacturing facilities for plastic products. We feel a strong sense of loyalty to Germany as our corporate site. For one thing, our long history means we have deep-rooted ties with the site. And for another, here in Teningen we have access to a highly skilled and motivated workforce who enable us to maintain our high quality standards.

From pioneer to market leader

GRAF has over 50 years' experience in the development and production of exceptionally high-quality plastic products. The company launched its first rainwater barrels in 1974 with the slogan 'Rainwater is free' and soon started marketing other products too. Since then GRAF has become the European market leader in rainwater harvesting, with over 200 utility models and patents.

Quality comes first

GRAF uses state-of-the-art production facilities. A high standard of quality in production is an essential foundation for unique products. End-to-end quality assurance and a high level of automation guarantee maximum reliability in production. Each individual tank is checked to make sure it meets our high standards. All production parameters as well as the workforce involved in the production process are documented for every single product. Because of our high standard of quality, we offer a warranty of up to 25 years on GRAF products.

Plastic – clear advantages over concrete

Plastic tanks are extremely durable and their smooth inner walls ensure consistently high water quality and easy cleaning. Their comparatively low weight reduces logistics and installation costs. Even larger sizes can be transported without the need for special vehicles. There is no need to assemble multiple parts on site.

99% availability guaranteed by modern logistics

GRAF products are exported around the globe. Intelligent logistics and good stock levels ensure first-class availability. Products are shipped from the logistics centres in Teningen (Germany) and Dachstein (France) to over 60 countries around the world.

Our goal: your satisfaction

Over one million customers worldwide already enjoy the advantages of GRAF products for water resource management. We feel confident that you will be equally inspired!



Teningen warehouse



Teningen logistics centre



Proven in numerous construction projects: GRAF Carat XXL underground tank



2 x 26,000 l (2 x 6,850 US gal.), Neu-Isenburg (DE)



26,000 l (6,850 US gal.), Baden-Baden (DE)



42,000 l (11,100 US gal.), Dortmund (DE)



56,000 l (14,750 US gal.), Bad Sauerbrunn (AT)



26,000 l (6,850 US gal.), Münchenstein (CH)



46,000 l (12,150 US gal.), Hendschiken (CH)

Carat XXL underground tank

The perfect combination of flexibility and stability



Available with a second tank dome as an option

On request the Carat XXL can be fitted with an additional dome. This increases the tank volume by 6,000 l (1,550 US gal.)

Lighter than concrete or steel

In spite of its large capacity, the Carat XXL has all the advantages of a plastic tank: its comparatively low weight reduces both logistics and installation costs.

Up to 76,000 l (20,050 US gal.) without abnormal load

Because the tank makes maximum use of the 2,5m wide loading space, a 76,000 l (20,050 US gal.) tank can be transported without the need for an abnormal load vehicle. Lifting straps are included in the delivery.

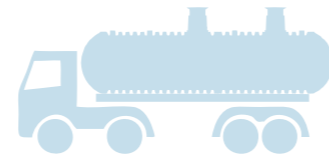

Suitable for lorry-bearing up to SLW 40

The GRAF Carat XXL underground tank can be driven over by vehicles of up to SLW 40 with an earth covering of 1000 mm (39.37").



Flexible connection up to DN 300 (12")

The rotating tank dome is easy to align with the connecting pipe. The telescopic tilting dome shaft makes it easy to align the tank with the level of the ground. Connecting faces up to DN 200 (8") are already fitted as standard. If necessary the Carat XXL can be fitted with connectors up to DN 300 (12"), either on the tank dome 1 or on the tank end 2.

Flexible in use

- Rainwater tank >> Page 8
- Retention cistern >> Page 14
- Firefighting water tank >> Page 16
- Wastewater tank >> see GRAF wastewater catalogue

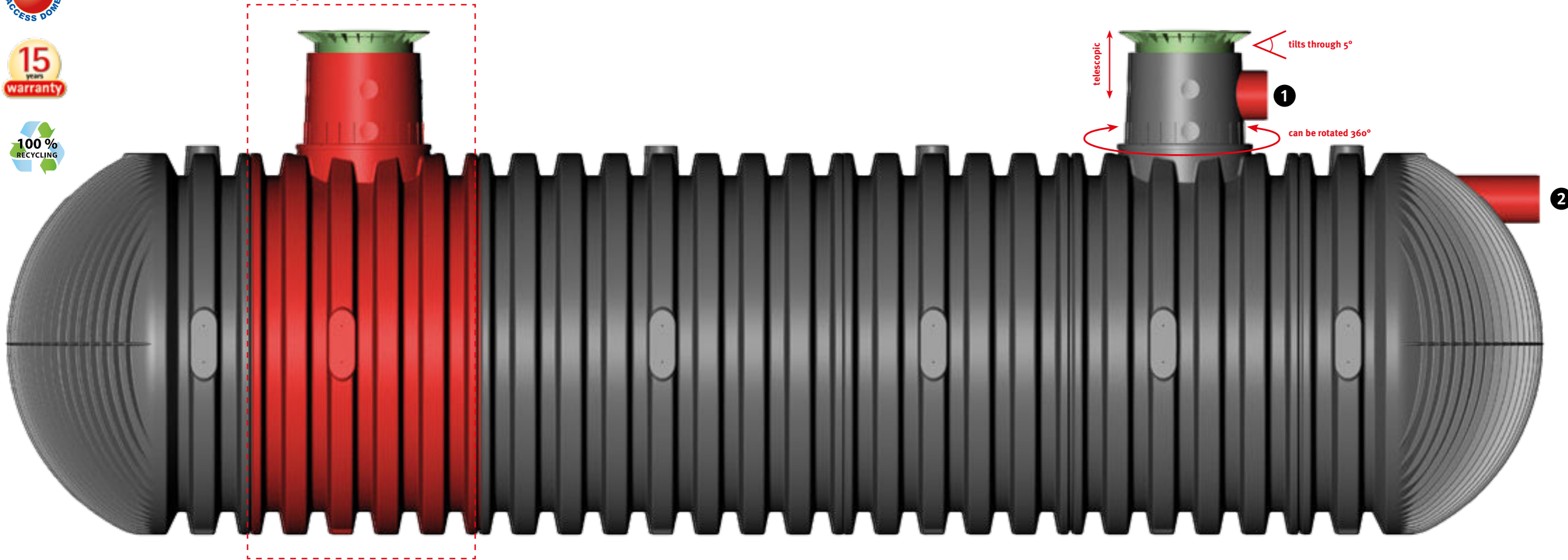
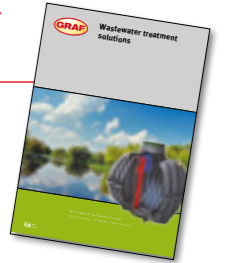

Delivery time by arrangement. Dispatched from the factory – shipping costs

Carat XXL underground rainwater tank

Up to 102,000 l (26,950 US gal.)



Carat XXL underground rainwater tank Suitable for vehicle/lorry-bearing¹⁾

- Suitable for lorry-bearing up to SLW 40
- Can be installed in groundwater
- Lower weight than concrete and steel
- Various connection surfaces
DN 100 (4")/150 (6")/200 (8")
- Larger connectors also available
- Second tank dome up to DN 300 (12")
also available
- Volumes up to 76,000 l (20,050 US gal.)
can be transported without abnormal
load vehicle

Q Webcode G1104



Lorry-bearing up to
SLW 40



Illustration shows 26,000 l (6,850 US gal.)
tank with telescopic dome shaft suitable for
lorry-bearing loading (see pages 18/19)

Tank
covers



>> page 18/19

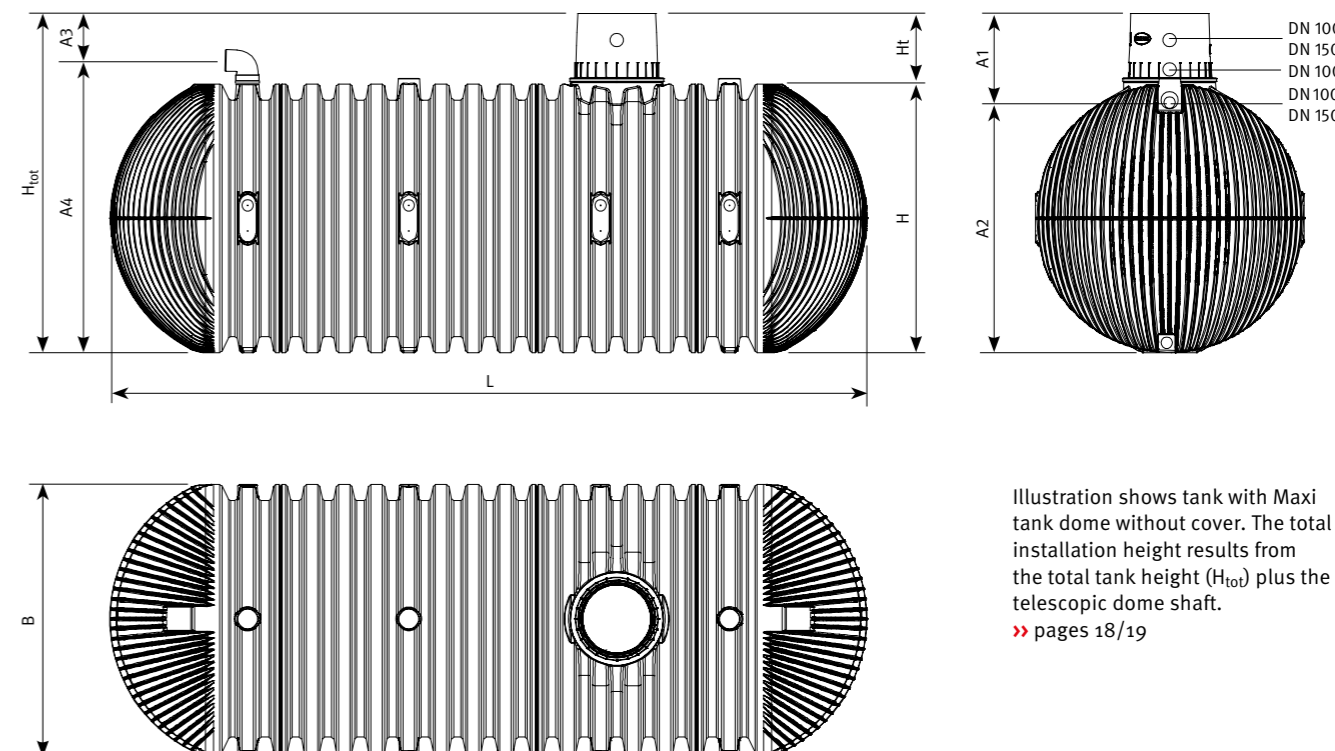

Illustration shows tank with Maxi
tank dome without cover. The total
installation height results from
the total tank height (H_{tot}) plus the
telescopic dome shaft.
>> pages 18/19

Also available as retention
cistern

>> page 14



Installation instructions
and dimensional drawings
available at
www.graf-online.de

Carat XXL underground rainwater tank

Volume [litres]	Width B [mm]	Length L [mm]	Height H_{tot} [mm]	Height H [mm]	Hight of tank dome Ht [mm]	Inner Ø of tank dome [mm]	Weight [kg]	Order no.
16,000	2500	4660	3160	2550	610	650	805	380001
22,000*	2500	6145	3160	2550	610	650	1015	380000
26,000	2500	7045	3160	2550	610	650	1150	380002
32,000*	2500	8530	3160	2550	610	650	1360	380003
36,000	2500	9430	3160	2550	610	650	1495	380004
42,000*	2500	10915	3160	2550	610	650	1705	380005
46,000	2500	11815	3160	2550	610	650	1840	380006
52,000*	2500	13300	3160	2550	610	650	2050	380007
56,000	2500	14200	3160	2550	610	650	2185	380008
62,000*	2500	15685	3160	2550	610	650	2395	380009
66,000	2500	16585	3160	2550	610	650	2530	380010
72,000*	2500	18070	3160	2550	610	650	2740	380011
76,000	2500	18970	3160	2550	610	650	2875	380012
82,000*	2500	20455	3160	2550	610	650	3085	380013
86,000	2500	21355	3160	2550	610	650	3220	380014
92,000*	2500	22840	3160	2550	610	650	3430	380015
96,000	2500	23740	3160	2550	610	650	3565	380016
102,000*	2500	25225	3160	2550	610	650	3775	380017

Scope of supply: Carat XXL underground rainwater tank with Maxi dome
Delivery time by arrangement. Dispatched from the factory – shipping costs on request

*with a second tank dome

¹⁾In conjunction with vehicle- or lorry-bearing cover

Connection dimensions

Volume [litres]	Connection A1 [mm]	Connection A2 [mm]	Connection A3 [mm]	Connection A4 [mm]
16,000	800	2360	435	2725
22,000*	800	2360	435	2725
26,000	800	2360	435	2725
32,000*	800	2360	435	2725
36,000	800	2360	435	2725
42,000*	800	2360	435	2725
46,000	800	2360	435	2725
52,000*	800	2360	435	2725
56,000	800	2360	435	2725
62,000*	800	2360	435	2725
66,000	800	2360	435	2725
72,000*	800	2360	435	2725
76,000	800	2360	435	2725
82,000*	800	2360	435	2725
86,000	800	2360	435	2725
92,000*	800	2360	435	2725
96,000	800	2360	435	2725
102,000*	800	2360	435	2725

*with a second tank dome

Technical data

Max. earth covering:	1500 mm (59")
Max. axle load:	8 t
Max. vehicle weight:	3.5 t with class B cast iron cover, 40t (SLW 40) with telescopic dome shaft lorry
Earth covering with loading capacity:	800 – 1500 mm (31.5" – 59")
Groundwater stability:	up to the middle of the tank
Earth covering with groundwater installation:	800 – 1500 mm (31.5" – 59")
Connection options:	DN 100 (4") – DN 200 (8") Optionally up to DN 300 (12")

Optimax XXL filter

- Water yield of over 95 %
- Self-cleaning filter principle
- Stainless steel filter insert with 0.35 mm (0.01") mesh
- Maximum catchment area 3000 m² with DN 300 (12") connections and 6000 m² with DN 400 (16") connections
- Patented filter technology
- Larger connections on request
- Includes cleaning unit
- Height loss of just 45 mm (1.75") between inlet and dirty water outlet

Webcode G2207

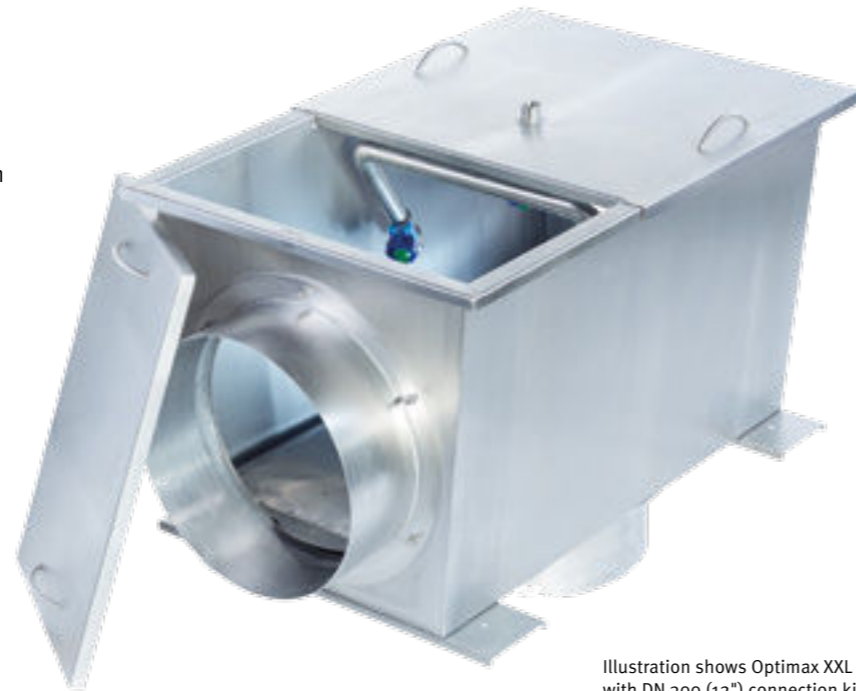

Illustration shows Optimax XXL with DN 300 (12") connection kit

Optimax XXL Filter Extern

Width [mm]	Length [mm]	Height [mm]	Weight [kg]	Order no.
675	1125	780	75	340096

Including filter cleaning unit

Consisting of four adjustable flat jet nozzles with a very powerful water jet to clean the filter screen. This means fewer maintenance intervals. Automatic control possible with Aqua Center Silentio.

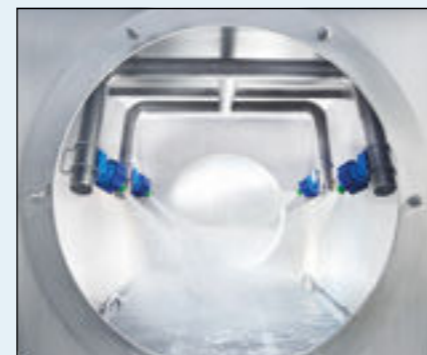

How the filter cleaning unit works

Accessories

DN 300 (12") connection kit
Order no. 340098

DN 400 (16") connection kit
Order no. 340100

Example installation*

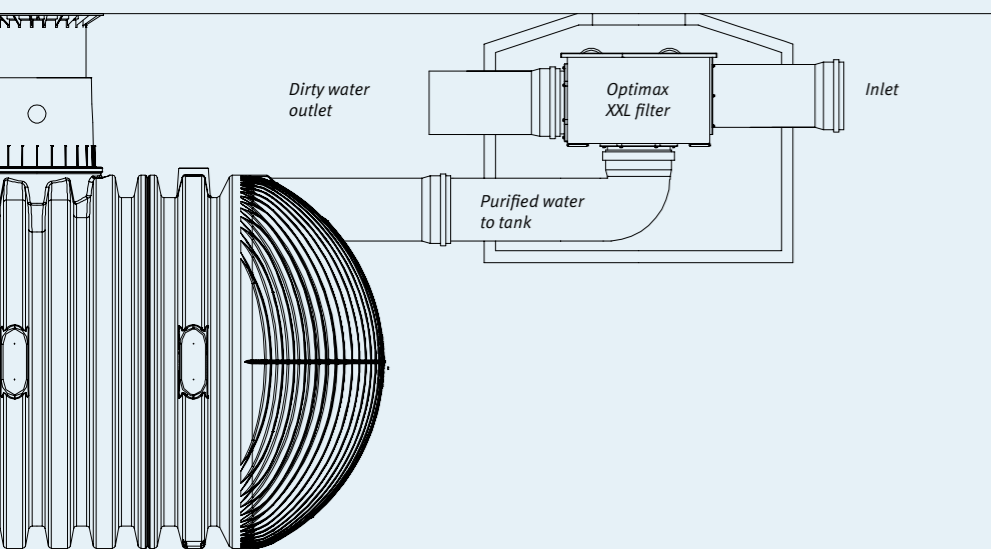

*Simplified representation

Add-on components



Overflow siphon

Connections DN	Width B [mm]	Length L [mm]	Height H [mm]	Weight [kg]	Order no.
150	275	445	355	2	330450
200	275	605	420	3	330451
300	400	955	660	12	330452

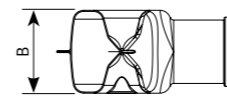

DN 150 (6")¹⁾

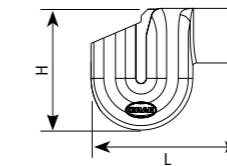

¹⁾with fitting

DN 200 (8") / DN 300 (12")²⁾

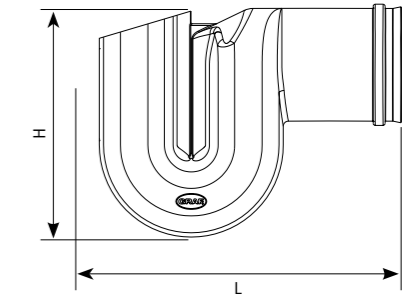

²⁾with sleeve



Calmed inlet digester

Connections DN	Width B [mm]	Length L [mm]	Height H [mm]	Weight [kg]	Order no.
150	200	400	180	1,5	330453
200 / 300	400	750	377	9,0	330454

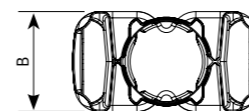

DN 150 (6")

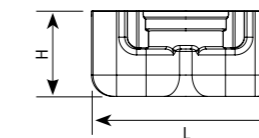

DN 200 (8") / DN 300 (12")

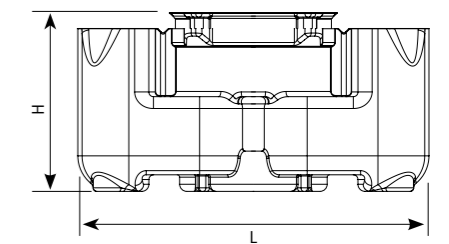



Drinking water feeding console

Incl. float switch, with 20 m (65' 7.5") connecting cable

- Low-cost private drinking water feed
- Float switch controlled
- High-quality KSB pump technology

Q [Webcode G3101](#)



Aqua Center Silentio

Incl. sensor, sensor line and 20 m (65' 7.5") data cable

- Optional automatic filter cleaning
- Automatic flushing of feed tank prevents build-up of bacteria
- Digital control and level measurement
- Display showing fill level and operating status

Q [Webcode G3102](#)



Properties	Drinking water feeding console		Aqua Center Silentio	
	15/4	25/4	15/4	25/4
Pump	15/4	25/4	15/4	25/4
Order no.	350021	350022	350209	350210
Rated power	0.66 kW	0.8 kW	0.66 kW	0.8 kW
Operating noise	55 dB(A)	55 dB(A)	49 dB(A)	49 dB(A)
Protection class	IP 44	IP 44	IP 44	IP 44
Operating pressure	3.5 bar	4.3 bar	3.5 bar	4.3 bar
Delivery height	35 m	43 m	35 m	43 m
Max. flow rate	3.6 m ³	4.2 m ³	3.6 m ³	4.2 m ³
Max. suction lift	6.0 m	6.0 m	6.0 m	6.0 m
Max. suction length	15 m	15 m	15 m	15 m
Operating pressure gauge	•	•	•	•
Optionally as Silentio Press package for distances of ≥ 15 m from house	-	-	•	•
Drinking water feed				
Volume	10 litres (2.64 US gal.)		6.5 litres (1.6 US gal.)	
Manual switchover to drinking water possible	•		•	
Automatic water exchange in feed tank	-		•	
Overflow according to DIN EN 1717	•		•	
Control				
Float switch	•		•	
Electronic level measurement	-		•	
Optional automatic filter cleaning	-		•	
Fault indicator	LED (on pressure monitor)		LED / full text	
Adjustable operating parameters	Drinking water feed threshold via float switch, start-up pressure		Drinking water feed threshold, start-up pressure, flushing interval / duration for drinking water feed tank and filter, filter flushing suppression in drinking water mode	
Dimensions				
Width	680 mm (27")		580 mm (23")	
Height	760 mm (30")		530 mm (21")	
Depth	210 mm (8.5")		295 mm (11.5")	
Weight	30 kg (66 lbs.)		34 kg (74 lbs.)	



DPA-IRM dual pump system

Incl. level sensor with 25 m (82' 0.3") connecting line, floating extraction 1 m (39.5"), 1 1/4", inspection kit

- Dual pump system with self-priming, horizontal centrifugal pumps
- Alternating start-up
- Second pump activated at peak extraction times
- Integrated dry running protection
- Protection against stagnation to German drinking water standards
- Digital control
- Pump system pressure gauge
- Rainwater level gauge
- Level sensor with 25 m (82' 0.3") connecting cable, also available with 50 m (164' 0.5") cable

Q [Webcode G3104](#)

Properties	DPA-IRM dual pump system			Feeder pump*
	C-class RM 6-40	C-class RM 8-40	C-class RM 14-40	Feeder pump
Pump	C-class RM 6-40	C-class RM 8-40	C-class RM 14-40	Feeder pump
Order no.	353002	353007	353009	355008
Rated power	2 x 700 W	2 x 880 W	2 x 1200 W	1100 W
Operating noise	-	-	-	-
Protection class	IP 44	IP 44	IP 44	IP 68
Operating pressure	4.2 bar	4.2 bar	4.7 bar	1.4 bar
Delivery height	42 m	42 m	47 m	14 m
Max. flow rate	6 m ³ /h	9 m ³ /h	14 m ³ /h	16.5 m ³ /h
Max. suction lift / suction length	Feeder pump required			-
Operating pressure gauge	•	•	•	-
Drinking water feed				
Volume	100 l (26.5 US gal.)	100 l (26.5 US gal.)	100 l (26.5 US gal.)	-
Manual switchover to drinking water possible	•	•	•	-
Automatic water exchange in feed tank	•	•	•	-
Overflow according to DIN EN 1717	•	•	•	-
Control				
Float switch	-	-	-	-
Electronic level measurement	•	•	•	-
Optional automatic filter cleaning	-	-	-	-
Fault indicator	•	•	•	-
Dimensions				
Width	570 mm (22.5")			160 mm (6")
Height	1540 mm (60.5") – 1560 mm (61.5") (adjustable)			474 mm (18.5")
Depth	665 mm (26")			-
Weight	100 kg (220 lbs.)	100 kg (220 lbs.)	100 kg (220 lbs.)	22 kg (48 lbs.)

Feeder pump*

High-quality stainless steel housing, 10 m (32' 9.7") connecting cable

Order no. 355008



Optional accessories:

Pressure sensor

50 m (164' 0.5") connecting cable

Order no. 355006

Diaphragm expansion tank

100 l (26.5 US gal.)

Order no. 355009

*must be ordered at the same time

Carat XXL retention cistern



ALSO AVAILABLE AS RETENTION PLUS UPON REQUEST

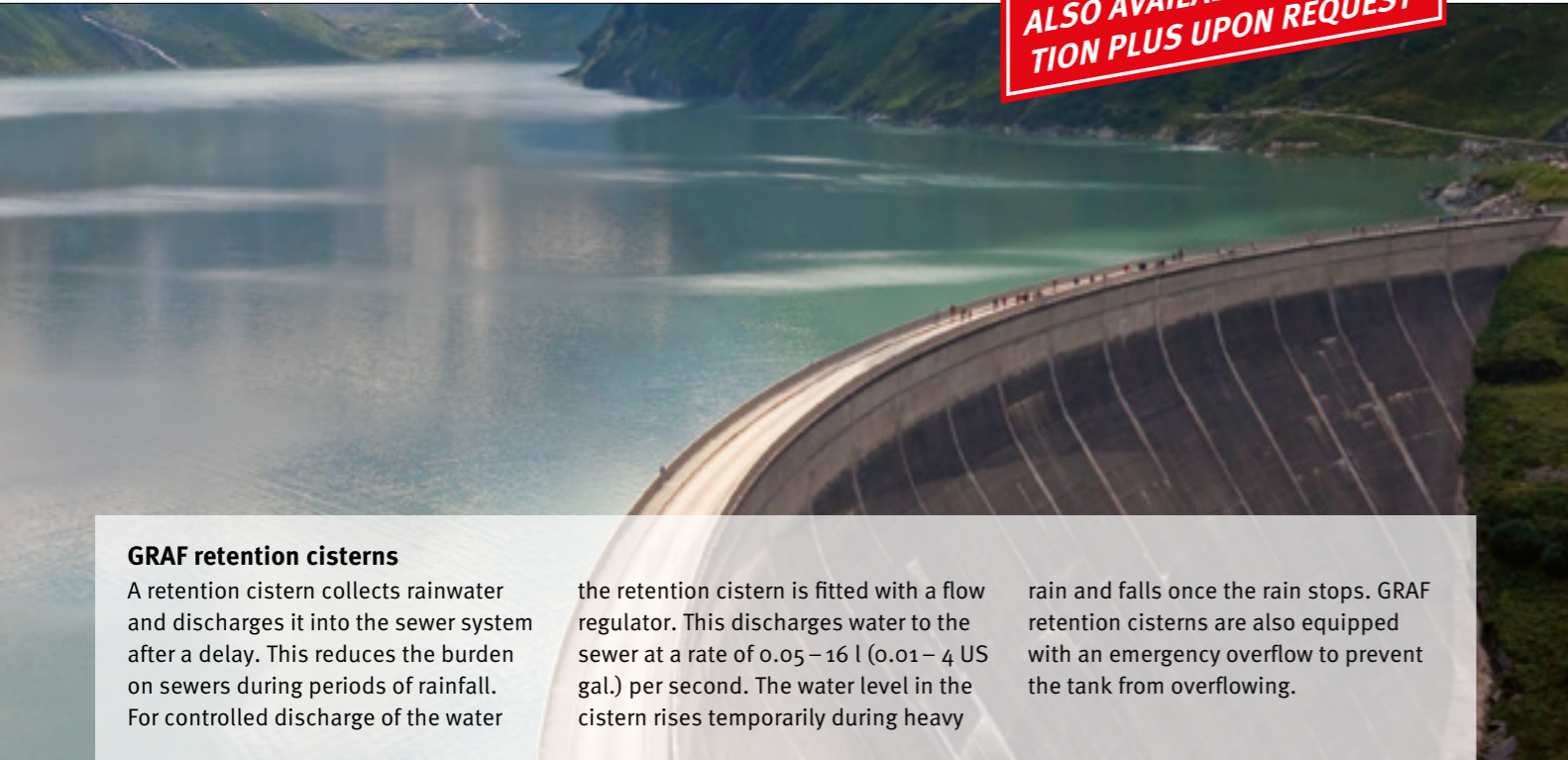

GRAF retention cisterns

A retention cistern collects rainwater and discharges it into the sewer system after a delay. This reduces the burden on sewers during periods of rainfall. For controlled discharge of the water

the retention cistern is fitted with a flow regulator. This discharges water to the sewer at a rate of 0.05 – 16 l (0.01 – 4 US gal.) per second. The water level in the cistern rises temporarily during heavy

rain and falls once the rain stops. GRAF retention cisterns are also equipped with an emergency overflow to prevent the tank from overflowing.

Retain water, save water: GRAF retention cisterns Plus

The GRAF retention cistern Plus is a combination of rainwater retention and rainwater harvesting. A larger tank is selected according to requirements,

allowing some of the rainwater can be used in addition to the required retention volume.

	Retention	Retention Plus
Rainwater retention	✓	✓
Rainwater harvesting		✓

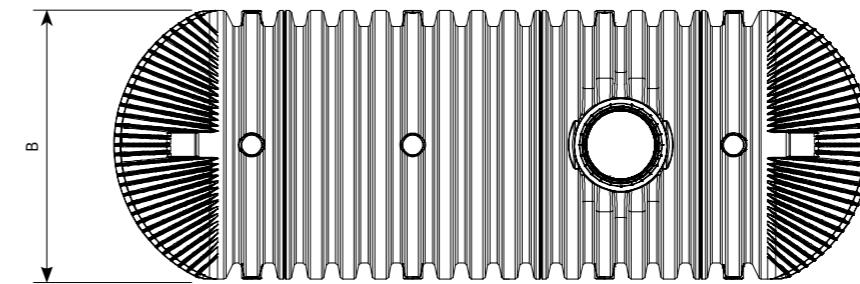
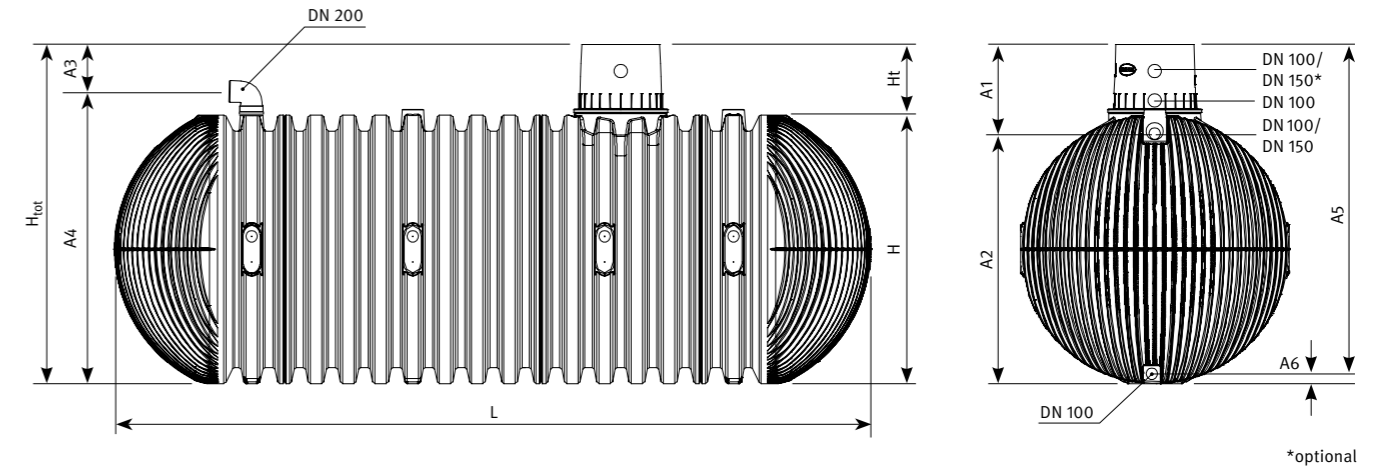

Illustration shows tank with Maxi tank dome without cover. The total installation height results from the total tank height (H_{tot}) plus the telescopic dome shaft.
 >> pages 18/19

Tank covers



>> page 18/19

Flow restrictor

For Carat XXL underground tank 0.05 – 2.0 l (0.01 – 0.53 US gal.) / sec., DN 100 (4") connection, 3 m hose

Best.-Nr. 369020

Other drainage rates available on request

Retentionszisterne / Retentionszisterne Plus Carat XXL

Volume [litres]	Width B [mm]	Length L [mm]	Height H_{tot} [mm]	Height H [mm]	Height of tank dome H_t [mm]	Inner \varnothing of tank dome [mm]	Weight [kg]	Retention Order no.	Retention Plus Order no.
16.000	2500	4660	3160	2550	610	650	805	380500	380520
22.000*	2500	6145	3160	2550	610	650	1015	380501	380521
26.000	2500	7045	3160	2550	610	650	1150	380502	380522
32.000*	2500	8530	3160	2550	610	650	1360	380503	380523
36.000	2500	9430	3160	2550	610	650	1495	380504	380524
42.000*	2500	10915	3160	2550	610	650	1705	380505	380525
46.000	2500	11815	3160	2550	610	650	1840	380506	380526
52.000*	2500	13300	3160	2550	610	650	2050	380507	380527
56.000	2500	14200	3160	2550	610	650	2185	380508	380528
62.000*	2500	15685	3160	2550	610	650	2395	380509	380529
66.000	2500	16585	3160	2550	610	650	2530	380510	380530
72.000*	2500	18070	3160	2550	610	650	2740	380511	380531
76.000	2500	18970	3160	2550	610	650	2875	380512	380532
82.000*	2500	20455	3160	2550	610	650	3085	380513	380533
86.000	2500	21355	3160	2550	610	650	3220	380514	380534
92.000*	2500	22840	3160	2550	610	650	3430	380515	380535
96.000	2500	23740	3160	2550	610	650	3565	380516	380536
102.000*	2500	25225	3160	2550	610	650	3775	380517	380537

Scope of supply: Carat XXL retention cistern with Maxi dome
 Delivery time by arrangement. Dispatched from the factory – shipping costs on request

*with a second tank dome

Connection dimensions

Volume [litres]	Connection A1 [mm]	Connection A2 [mm]	Connection A3 [mm]	Connection A4 [mm]	Connection A5 [mm]	Connection A6 [mm]
16.000	800	2360	435	2725	3070	90
22.000*	800	2360	435	2725	3070	90
26.000	800	2360	435	2725	3070	90
32.000*	800	2360	435	2725	3070	90
36.000	800	2360	435	2725	3070	90
42.000*	800	2360	435	2725	3070	90
46.000	800	2360	435	2725	3070	90
52.000*	800	2360	435	2725	3070	90
56.000	800	2360	435	2725	3070	90
62.000*	800	2360	435	2725	3070	90
66.000	800	2360	435	2725	3070	90
72.000*	800	2360	435	2725	3070	90
76.000	800	2360	435	2725	3070	90
82.000*	800	2360	435	2725	3070	90
86.000	800	2360	435	2725	3070	90
92.000*	800	2360	435	2725	3070	90
96.000	800	2360	435	2725	3070	90
102.000*	800	2360	435	2725	3070	90

*with a second tank dome

Technical data

Max. earth covering:	1500 mm (59")
Max. axle load:	8 t
Max. vehicle weight:	3.5 t with class B cast iron cover, 40 t (SLW 40) with telescopic dome shaft lorry
Earth covering with loading capacity:	800 – 1500 mm (31.5" – 59")
Groundwater stability:	up to the middle of the tank
Earth covering with groundwater installation:	800 – 1500 mm (31.5" – 59")
Connection options:	DN 100 (4") – DN 200 (8") Optionally up to DN 300 (12")

Carat XXL firefighting water tank



- Delivery includes all firefighting water accessory parts to DIN 14230
- Complete system fully factory-assembled if required – no on-site assembly
- Dome shaft allows easy access / rescue from tank
- Individual tanks can be enlarged / connected to create large volumes
- Fill with drinking water or rainwater
- Individual adjustment to ground level (earth covering / angle of slope)
- Low procurement costs

- Incl. telescopic dome shaft lorry to DIN 3223

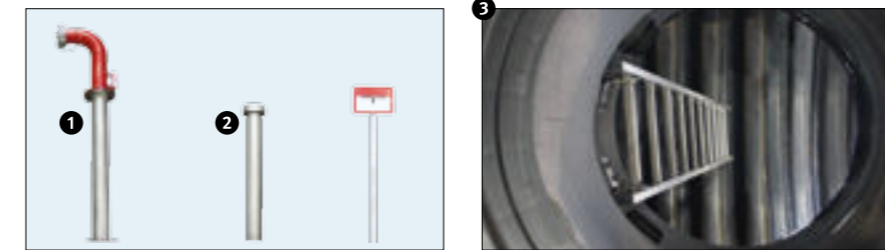
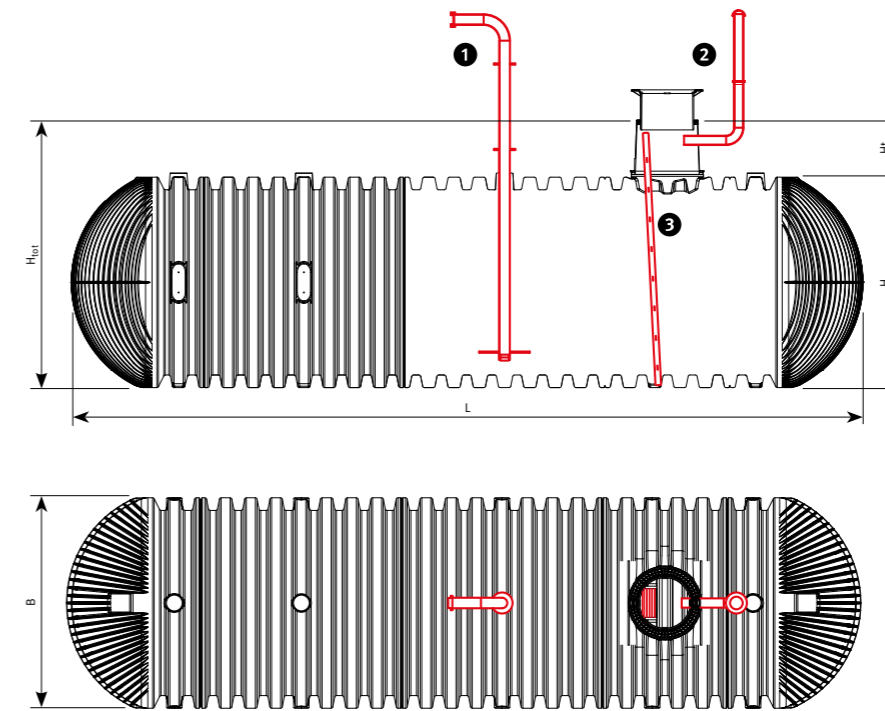

Carat XXL firefighting water tank

Rated volume [litres]	Useful volume [litres]	Width B [mm]	Length L [mm]	Height H _{tot} [mm]	Height H [mm]	Hight of tank dome Ht [mm]	Inner Ø of tank dome [mm]	Weight [kg]	Order no.
16.000	14.400	2500	4660	3160	2550	610	650	805	380050
22.000*	19.800*	2500	6145	3160	2550	610	650	1015	380051
26.000	23.400	2500	7045	3160	2550	610	650	1150	380052
32.000*	28.800*	2500	8530	3160	2550	610	650	1360	380053
36.000	32.400	2500	9430	3160	2550	610	650	1495	380054
42.000*	37.800*	2500	10915	3160	2550	610	650	1705	380055
46.000	41.400	2500	11815	3160	2550	610	650	1840	380056
52.000*	46.800*	2500	13300	3160	2550	610	650	2050	380057
56.000	50.400	2500	14200	3160	2550	610	650	2185	380058
62.000*	55.800*	2500	15685	3160	2550	610	650	2395	380059
66.000	59.400	2500	16585	3160	2550	610	650	2530	380060
72.000*	64.800*	2500	18070	3160	2550	610	650	2740	380061
76.000	68.400	2500	18970	3160	2550	610	650	2875	380062
82.000*	73.800*	2500	20455	3160	2550	610	650	3085	380063
86.000	77.400	2500	21355	3160	2550	610	650	3220	380064
92.000*	82.800*	2500	22840	3160	2550	610	650	3430	380065
96.000	86.400	2500	23740	3160	2550	610	650	3565	380066
102.000*	91.800*	2500	25225	3160	2550	610	650	3775	380067

Delivery time by arrangement. Dispatched from the factory – shipping costs on request

*with a second tank dome

Technical data

Max. earth covering:	1500 mm (59")
Max. axle load:	8t
Max. vehicle weight:	40t (SLW 40)
Earth covering with loading capacity:	1000 mm – 1500 mm (39.5" – 59")
Groundwater stability:	up to the middle of the tank
Earth covering with groundwater installation:	800 – 1500 mm (31.5" – 59")
Connection options:	DN 100 (4") – DN 200 (8") Optionally up to DN 300 (12")



DN 250 (10") connection fitting
To connect multiple Carat XXL firefighting water tanks (optionally up to DN 300 (12"))
Order no. 360023

Scope of supply:

1 Welded-in plastic intake pipe DN 125 (5") with flange, stainless steel strainer and anti-vortex plate, including stainless steel intake pipe extension piece DN 125 (5") with flange, firefighting water intake connection with rod fitting and A fixed coupling to DIN 14244. 2 stainless steel ventilation chimney DN 100 (4") with hood and insect-proof screen for vertical installation, 3 access ladder incl. mounting kit for mounting in tank dome, holder for sign "Firefighting Water Extraction Point" with stainless steel post to DIN 4066 (B2), telescopic dome shaft lorry to DIN 3223



Mini telescopic dome shaft

- with PE cover
- suitable for pedestrian loading
- Weight: 9 kg (19 lbs.)
- Adjustable earth covering across upper tank surface

plus 140 – 340 mm (5.5" – 13.5") earth covering
Order no. 371010

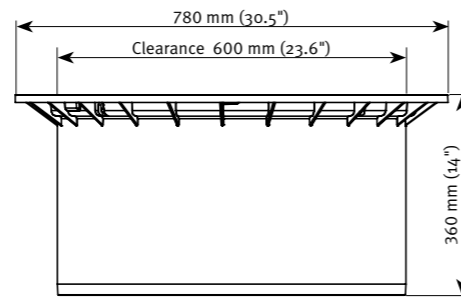

Maxi telescopic dome shaft

- with PE cover
- suitable for pedestrian loading
- Weight: 15 kg (33 lbs.)
- Adjustable earth covering across upper tank surface

plus 140 – 440 mm (5.5" – 17") earth covering
Order no. 371011

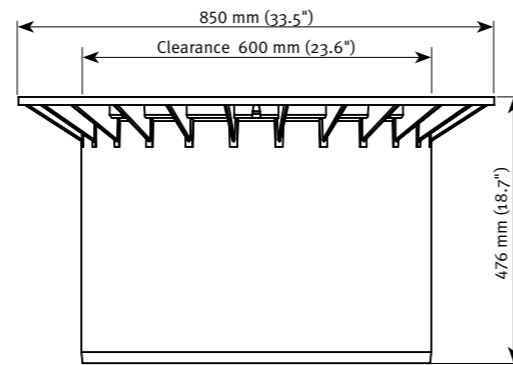

Cast iron telescopic dome shaft

- Suitable for vehicle loading – with childproof Class B cast iron cover
- Weight: 55 kg (121 lbs.)
- Adjustable earth covering across upper tank surface

plus 140 – 440 mm (5.5" – 17") earth covering
Order no. 371020

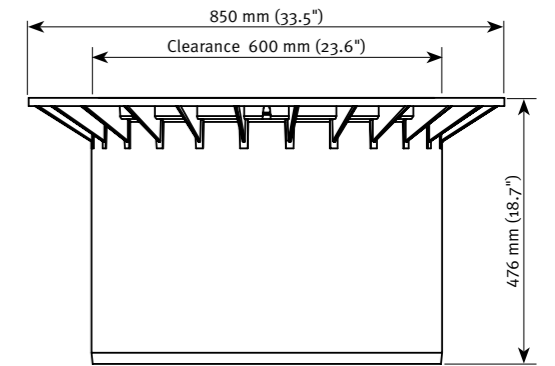

Telescopic dome shaft lorry

- Suitable for vehicle/lorry-bearing loading
- Weight: 11 kg (24 lbs.)
- Cover to be provided on site
- Adjustable earth covering across upper tank surface
- For commercially available concrete rings/covers (to be provided on site)
- Ideal for asphalt surfaces

plus 140 – 440 mm (5.5" – 17") earth covering
Order no. 371021

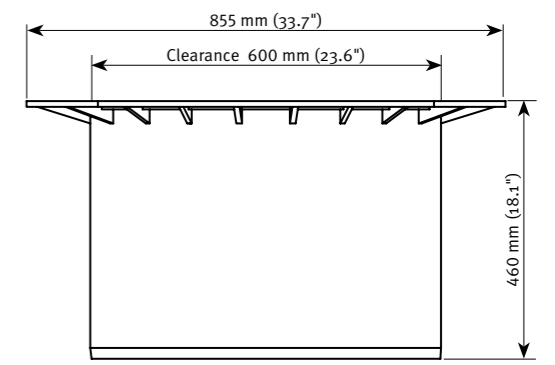

Has to be provided by client



Spacer for shafts and domes

- Weight: 6 kg (13 lbs.)
- The earth covering can be raised 300 mm using the spacer.

Order no. 371003

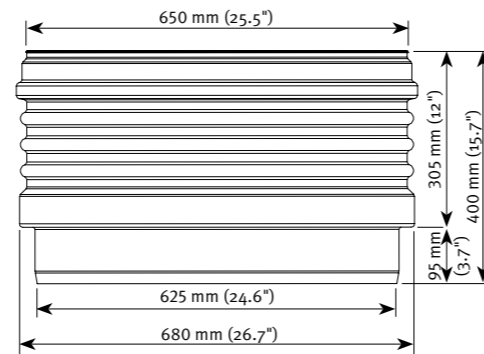

Cover suitable for vehicle loading permits installation under driveway.



Lorry-bearing telescopic dome shaft allows standard concrete rings and covers to be used.

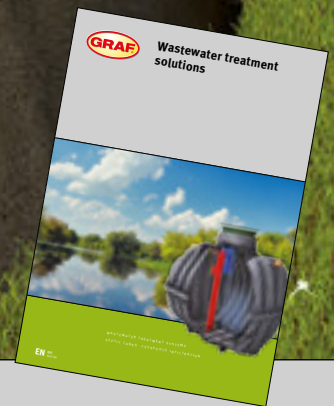

RAINWATER HARVESTING



INFILTRATION



WASTEWATER TREATMENT SOLUTIONS



MULTIPURPOSE CONTAINERS



Wastewater treatment solutions

For more information about our wastewater treatment solutions, ask for our catalogue.

Prices:

A price list with our export conditions is available on request.

Warranty clause:

The warranty mentioned in this brochure only refers to the tank in question and not to the accessories. Within the warranty period we grant free replacement of the material. Further benefits are excluded. Pre-condition for warranty benefits are proper handling, assembly and installation according to the mounting guidelines.

N.B. Protect tanks from frost when installed above ground! In case of groundwater installation, please contact us for further information prior to purchase!

For all dimensions and abstracts provided in this brochure, we reserve a tolerance of $\pm 3\%$. Depending on the connection type, the useful volume of the underground tanks may be up to 10% below the tank capacity.

Subject to technical modifications and errors. Design details, methods and standards of individual products may change as a result of technical advancements and environmental regulations.

For all our offers and conclusions of contract, only our General Terms and Conditions of Business dated 01/03/2012 shall apply, which we will send to you on request.

Photo copyright: Fotolia.com:
© Zechal (page 14), © benjaminmolte (page 16)

Your expert specialist dealer:

Otto Graf GmbH
Kunststoffzeugnisse
Carl-Zeiss-Straße 2-6
79331 Teningen, Germany

Phone: +49 7641 589-0
Fax: +49 7641 589-50
mail@graf.info
www.graf-water.com

Graf UK Ltd
Target House
Thorpe Way Industrial
Estate
Banbury

Oxfordshire
OX16 4SP
Phone: +44 1608 661-500
info@grafuk.co.uk
www.grafuk.co.uk

© Otto Graf GmbH, Teningen, Germany
Reproduction – even in extracts –
only with written authorisation
Item no. 950358/EN